



- ABS hand held enclosure for data acquisition and instrumentation
- With integrated battery compartment
- Version with or without display openings
- Prepared for acceptance of keypads/silicone switch mats
- 2 depth variants
- Optional EMC version with internal coating

Included in delivery

Enclosure with top and base, keyboard surround, head and shaft surround, fastening and enclosure screws. Open version incl. display screen and punched seal.
Please order battery compartment separately.

Technical data

Material:

ABS

Ingress protection:

IP 40 to EN 60529

Surface resistance:

4×10^{14} Ohm, IEC 60093

Flammability:

HB / UL 94

Colour:

upper/lower mould, battery compartment cover, head/shaft surround: RAL 5020, ocean blue
keyboard surround, battery compartment/
battery pack: RAL 7024, graphite grey

Temperature range:

-40°C to +80°C

Taguan 180/230

Programme range

Enclosure type	Order No.	Version	Dimensions	Weight (kg)
			W x L x H (mm)	
Taguan 180 O	27.01 04 00	open	84/70 x 180 x 52.5/37.5	0.17
Taguan 180 G	27.01 04 01	closed	84/70 x 180 x 52.5/37.5	0.12
Taguan 230 O	27.01 06 00	open	97/70 x 229 x 52.5/37.5	0.15
Taguan 230 G	27.01 06 01	closed	97/70 x 229 x 52.5/37.5	0.16



Electromechanical and electronic components

Upon request we can supply enclosures ready equipped with electromechanical and electronic components such as display, chipcard-acceptor, interface modules etc.

Accessories

Battery holder for 9 V monoblock	27.01 00 94	Hand strap (T 180)	27.01 04 84
Shaft cover in enclosure colour	27.01 02 85	Hand strap (T 230)	27.01 06 84
Shaft cover transparent	27.01 02 86	Spare display screen set (T 180)	27.01 04 88
Shaft cover for infrared	27.01 02 87	Spare display screen set (T 230)	27.01 06 88
Battery compartment empty, 0.03 kg	27.01 00 80	Spare screws	27.01 00 90
Battery pack NiMH 4.8 V / 2100 mAh	27.20 00 03	Head cover, stepped, in enclosure colour	27.01 00 85
Connector charger	27.20 00 02	Head cover, stepped, for infrared	27.01 00 87
Battery charging station	27.20 00 01	Head cover, stepped, transparent	27.01 00 89
Spring contact, 2-pole	27.01 00 82	Head cover, straight, in enclosure colour	27.01 00 91
Wrist strap	27.01 00 83	Head cover, straight, transparent	27.01 00 92
Display fixing set (T 180)	27.01 04 80	Head cover, straight, for infrared	27.01 00 93
Display fixing set (T 230)	27.01 06 80	Scratch resistant display screen	on request
Switch mat set 12 keys	27.01 00 95	Push-button and switches see page 53 - 58	on request
Switch mat set 24 keys	27.01 04 81		
Switch mat set 36 keys (T 230)	27.01 06 81		

Component mounting options

Component options	Type	Type	Type	Type
	T180 O	T180 G	T230 O	T230 G
Display (max. view area 56 x 33 mm; max. mounting dimensions 66 x 46 mm)	•			
Display (max. view area 66 x 43 mm; max. mounting dimensions 78 x 56 mm)			•	
Chipcard reader in head section	•	•	•	•
Chipcard reader in shaft section	•	•	•	•
Magnetic card reader	•	•	•	•
Scanner	•	•	•	•
PCMCIA slot	•	•	•	•
D-Sub interface 9-pin	•	•	•	•
D-Sub interface 15-pin	•	•	•	•
D-Sub interface 25-pin	•	•	•	•
Battery pack	•	•	•	•
4 micro-cells R6 (AA)	•	•	•	•
9 V battery	•	•	•	•
1st board (main board)	•	•	•	•
2nd board (adapter board)	•	•	•	•
Membrane keypad	•	•	•	•
Switching mat, 12 keys, in combination with keypad plate	•	•	•	•
Switching mat, 24 keys	•	•		
Switching mat, 36 keys			•	•

Dimensions



Type	Version	Order No.
Taguan 180 O	open	27.01 04 00
Taguan 180 G	closed	27.01 04 01

(max. PCB size of displays ca. 66 x 46 mm)

* = Open version
 ** = PCB mounting boss (screw 2.5 x 5)

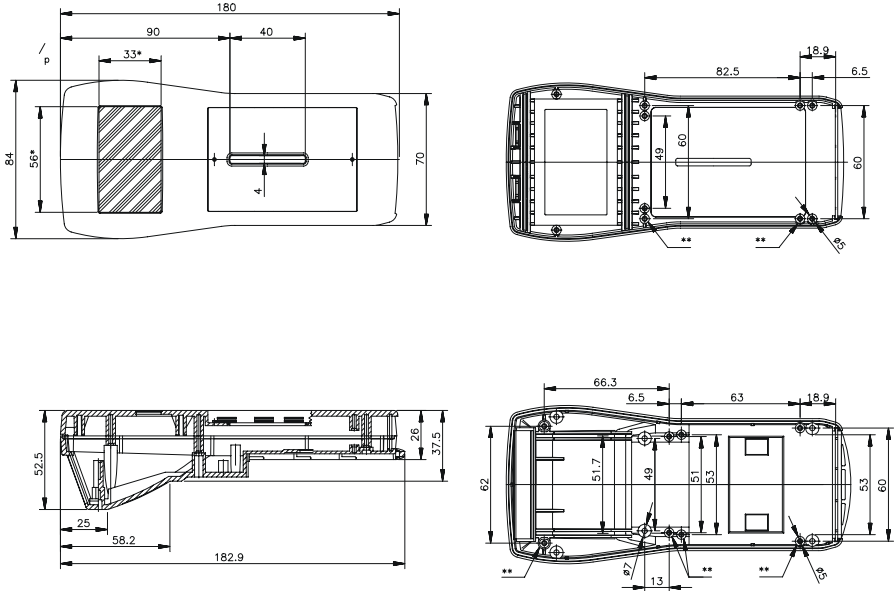

Type	Version	Order No.
Taguan 230 O	open	27.01 06 00
Taguan 230 G	closed	27.01 06 01

(max. PCB size of displays ca. 78 x 56 mm)

* = Open version
 ** = PCB mounting boss (screw 2.5 x 5)

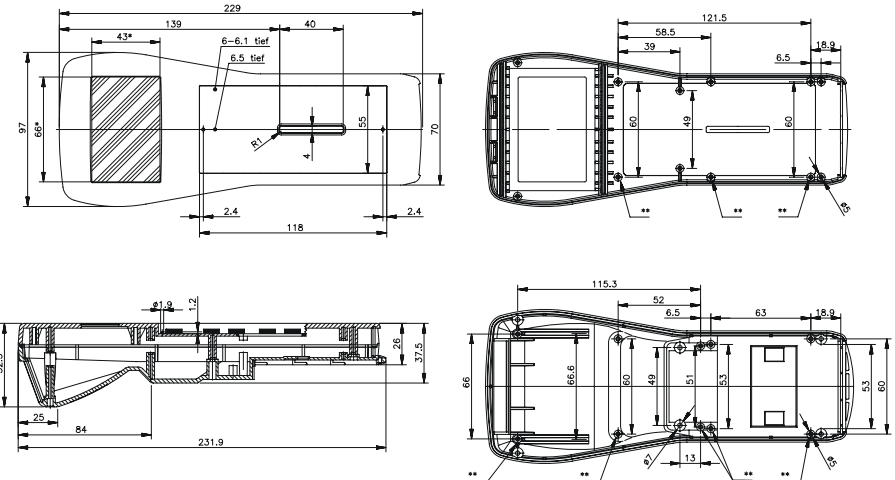

Accessories



Battery compartment empty
consisting of battery compartment and lid space for 4 micro-cells R6 (AA) side by side

Order No. 27.01 00 80

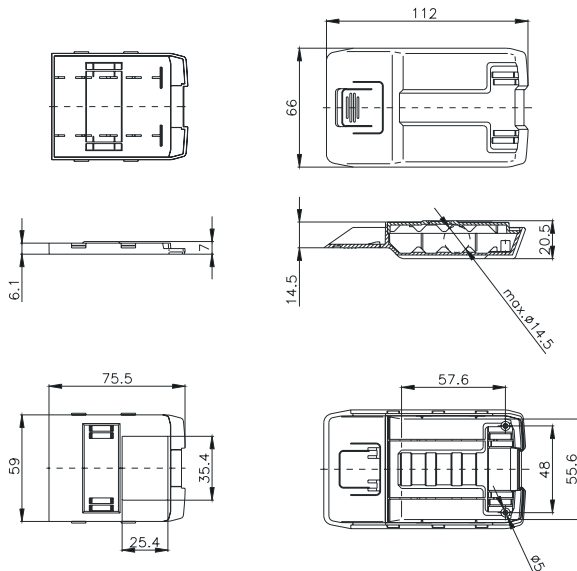

Battery pack
NiMH 4.8 V / 2100 mAh

Order No. 27.20 00 03

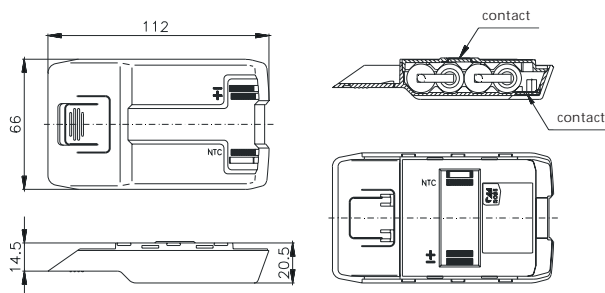

Battery holder
for mounting in the bottom part for 9 V monobloc.

Order No. 27.01 00 94

Accessories



Connector charger with primary adapter

Order No. 27.20 00 02

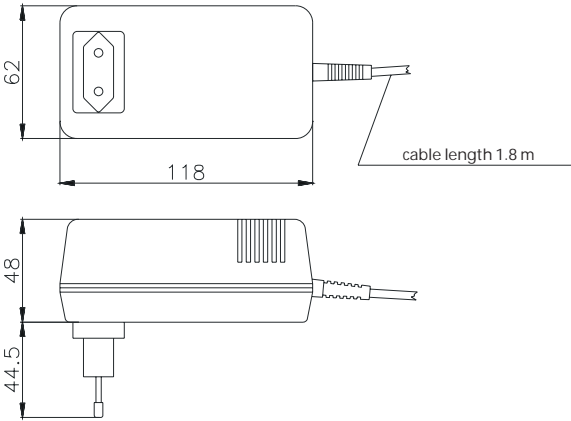

Battery charging station

Order No. 27.20 00 01

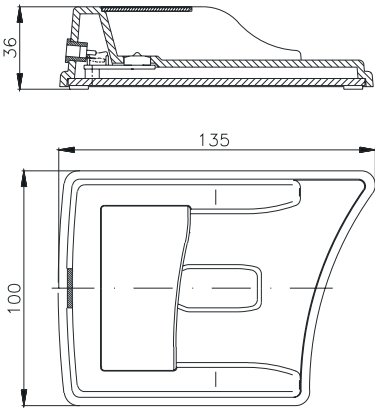

Accessories



Spring contact 2-pol.

Counter-contacts for the battery pack (Company Bourns, type 70ADJ002ML1), for mounting in enclosure bottom part

Order No. **27.01 00 82**

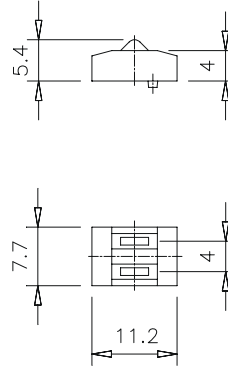

Head cover

Version	Order No.
stepped in enclosure colour	27.01 00 85
stepped transparent	27.01 00 89
stepped for infrared	27.01 00 87
even in enclosure colour	27.01 00 91
even transparent	27.01 00 92
even for infrared	27.01 00 93

units per pack: 1 pc

even

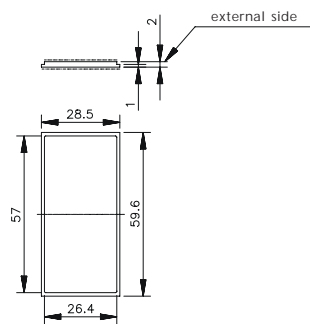

stepped

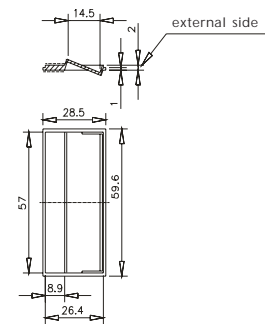

Accessories



Shaft cover

Version	Order No.
in enclosure colour	27.01 02 85
transparent	27.01 02 86
for infrared	27.01 02 87

units per pack: 1 pc

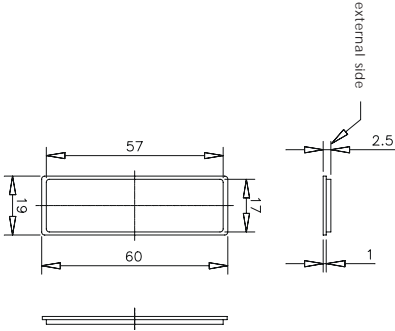

Switching mat set

consisting of keypad plate, silicone switching mat and keypad circuit board with connecting cable

for type	No. of keys	Order No.
Taguan 180/230	12*/**	27.01 00 95
Taguan 180	24**	27.01 04 81
Taguan 230	36	27.01 06 81

* Please remember the modification of the toppart for the flat cable
 ** Please not different heights by combination with closed cover

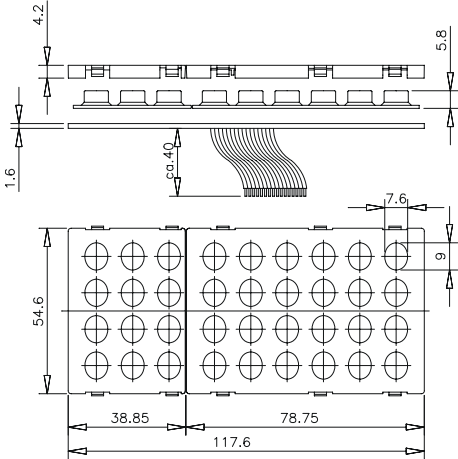

Accessories



Display fixing set
for variable display mounting



Hand strap
with Velcro fastener for adjustment, consisting of holding strap, adapter and screws



Wrist strap
to prevent falling down, or as carrying aid

Order No. 27.01 00 83

Version for	Order No.
Taguan 180	27.01 04 80
Taguan 230	27.01 06 80

Version for	Order No.
Taguan 180	27.01 04 84
Taguan 230	27.01 06 84